



BONGARD

Always by your side

TRAY CONVECTION OVEN

KRYSTAL+

A compact, reliable oven
for easy integration



MADE IN FRANCE



KRYSTAL+ is an electric convection oven that can hold baking trays measuring 400 mm wide and 600 or 800 mm deep and is fitted with 4, 9 or 10 levels.

Compact and reliable, **KRYSTAL+** easily fits into small spaces. Its **versatility** provides perfect baking conditions for a very wide range of bakery products and pastries, including the lightest and most delicate products.

Its SENSITIV'2 touchscreen control panel makes operation simple and intuitive, supporting superior comfort of use for all bakers and pastry chefs.



Reliable

Compact

Practical

Smart

Versatile



A compact oven

With a width of 780 mm, **KRYSTAL+** easily fits into small spaces and offers numerous configuration possibilities. Its stand can include tray storage, a drawer or a proofer, and castors can be added for **easier moving**.



A smart oven

The SENSITIV'2 touchscreen control panel opens up new possibilities with its Recipe mode, production reports and user profile management, ensuring accessible, **simple and intuitive operation**.

The "Delayed start" function enables users to define the exact time the oven must reach a specific temperature and is complemented by the "Energy Saving" function, which automatically switches the oven to standby after a predefined period of inactivity, ensuring **optimised energy consumption**.



A versatile oven

KRYSTAL+ makes it possible to bake all kinds of bakery and pastry products to perfection. The Ventilation Speed Variation function is perfect for the lightest, most delicate products, like macarons, as it offers **suitably gentle baking**.



An oven carefully designed to respond to the needs of bakers and pastry chefs



Hood with extractor* or condenser* (options)

Double-glazed glass and infrared treatment for superior internal heat retention

Fresh air inlet, adjustable via a pull tab under the door, to optimise moisture evacuation



Moving and cleaning made easy by the castors

"Partial Load" function in case of reduced production



Programmable steam vent to control steam exhaust



Stand with tray storage or proofer* (options)

*except KRYSTAL + 46.4 L, only available with tray storage

Work in complete safety with KRYSTAL+



Our commitment to safety goes beyond self-certification, as we have our equipment audited by an independent external body.

Fast and intuitive control panel

KRYSTAL+ comes fitted with the SENSITIV'2 touchscreen control panel so the oven's operation can be intelligently managed via its 7" screen.

Its clear, illustrated interface enables easy operation and offers a wide range of settings.

Depending on your needs, the oven can also be equipped with an electromechanical Ergocom control panel.

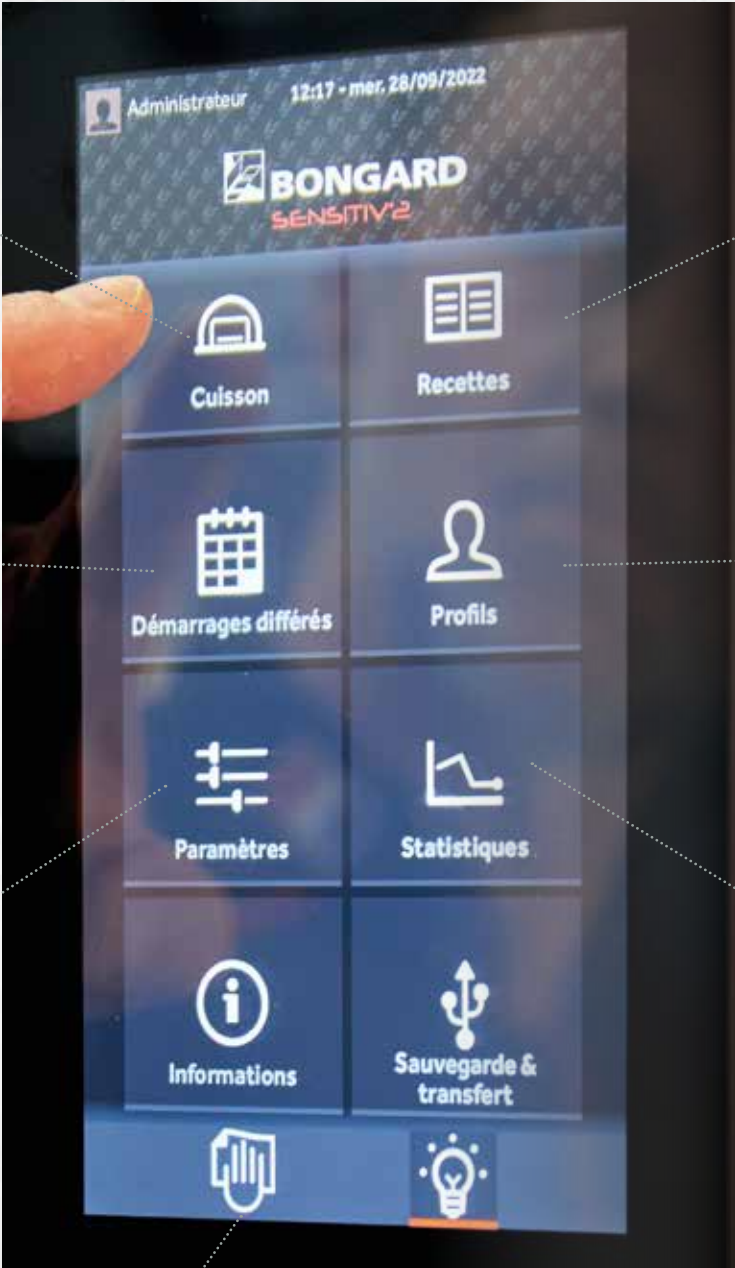

Create recipes (temperature, time, steam injection and steam vent management)



Manage custom permissions depending on the user profile (authorisation or not to modify the saved recipes, access settings, etc.)

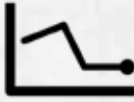

Consult statistics on the oven's production and energy use



Manage baking in manual mode or in Recipe mode



Schedule delayed baking starts for each day

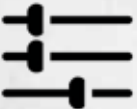

Customise the oven and access the "Energy Saving" function



Temporarily disable the touchscreen to clean the control panel

Our experts at your service

Sales expertise

Our sales and installation teams can help you decide on the best equipment and layout for your production process and offer support at every stage of your project.

For the French market, we also offer financial leasing solutions through a dedicated division, Bongard Finance. This agile financing method preserves cash flow and is a first in the bakery and pastry goods market.

Business expertise

At our head office in Holtzheim, France, we have a 320 m² showroom and laboratory where you can come and try out our equipment in line with your own production processes. Contact us to arrange a visit.

Wherever you are in the world, we can arrange for our master bakers to visit your premises and train you on our machines.

Technical expertise

Our equipment is covered by the manufacturer's warranty from the moment of delivery. To optimise the service life of your equipment and avoid costly downtime, you can also take out a maintenance contract and/or an extended guarantee.

The technicians at our dealerships and distributors receive regular training so they are fully qualified to keep your equipment in good working order.

Our dealers and distributors have access to an online platform where they can consult technical documentation and order spares from a catalogue of around 5000 original parts, which ship within 24 to 48 hours.



Technical data

	KRYSTAL+ 46.4	KRYSTAL+ 46.4 L	KRYSTAL+ 46.9	KRYSTAL+ 46.10	KRYSTAL+ 48.4	KRYSTAL+ 48.9	KRYSTAL+ 48.10
Support							
Support dimensions (mm)	400 x 600				400 x 800		
Number of levels	4	4	9	10	4	9	10
Door opening direction							
Handle on the left		•				•	
Handle on the right		o				o	
Type of control							
SENSITIV'2 (with Partial load and Ventilation speed variation)		•				•	
Ergocom		- €				- €	
Steam							
Without steam generator	- €	-	-	•	-	-	•
With steam generator	•	•	•	-	•	•	-
Anti-scale filtration kit and/or pressure reduction kit	€		€	-	€	€	-
Accessories (upper section)							
Hood with <u>or</u> without steam extractor fan	€	-	€	€		€	
Hood with steam condenser <u>or</u> wall-mounted condenser	€	-	€	€		€	
Accessories (lower section)							
Stand: tray storage with drawer, with <u>or</u> without castors (H = 850 mm)	€	-	€	€		€	
Stand: tray storage with drawer and castors (H = 970 mm)	€	€	€	€		€	
Proofbox without drawer or castors (H = 850 mm)	€	-	€	€		€	
Proofbox with drawer and castors (H = 970 mm)	€	-	€	€		€	
Power supply voltage (oven)							
3N~400 V (standard power)			•			•	
3N~400 V (reduced power)			o			o	
3~230 V			o			o	
Power supply voltage (extractor and condenser)							
1N~230 V	•	-	•	•		•	
Connection capacity (kW)							
Of the oven (if standard power)	10.3	10,3	18.6	18.6	10.3	18.6	18.6
Of the oven (if reduced power)	6.9	6,9	12.5	12.5	6.9	12.5	12.5
Dimensions (mm)							
Oven height (A)	530	530	1055	1055	530	1055	1055
Height of stand / proofbox (B1 <u>or</u> B2)	850 <u>ou</u> 970	970	850 <u>ou</u> 970	850 <u>ou</u> 970		850 <u>ou</u> 970	
Oven depth (C)	1145	995	1145	1145		1340	
Depth of oven with hood (D)	1465	n/a	1465	1465		1660	
Depth of oven, door open (E)	1700	1415	1700	1700		1895	
Width (F)	780	919			780		

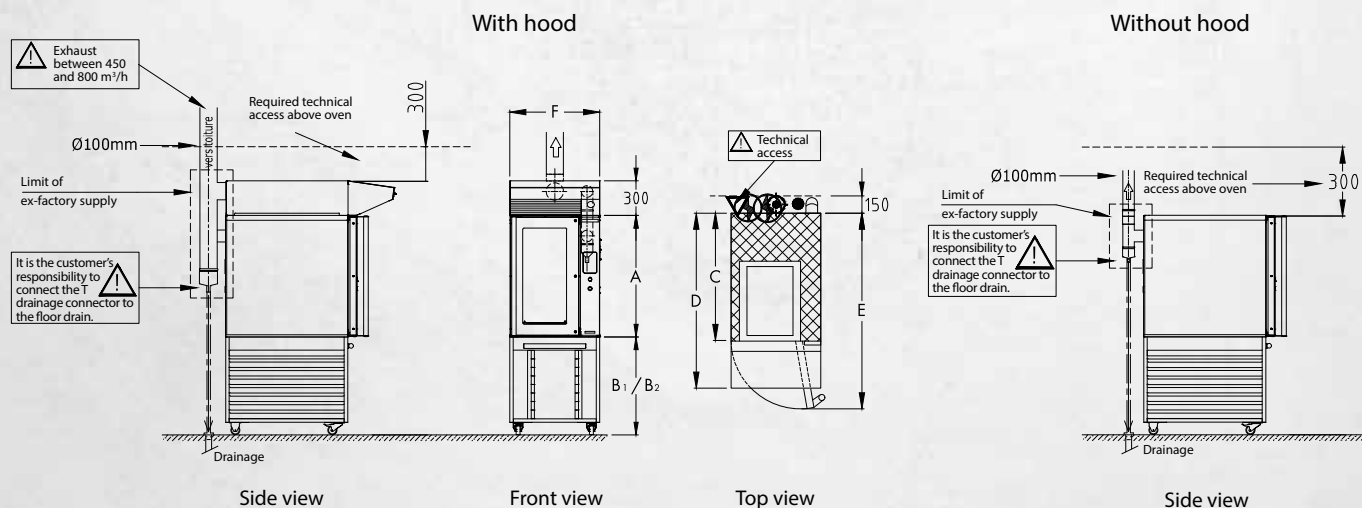

• : Standard | o : Free option | € : Option with extra charge | - : Unavailable | - € : Reduction



BONGARD

Always by your side

BONGARD is a French company that has been manufacturing bakery equipment since 1922. We have established a network of exclusive dealers who provide commercial and technical services throughout France and in the French overseas departments and territories. All dealers receive regular training on all our product ranges. We also have distributors in more than 140 countries around the world.

To find a distributor near you, please go to:
<https://www.bongard.fr/en/distributor/>



Follow us:

 Bongard.bakery

 Bongard_bakery

 BongardBakery

 Bongard

BONGARD

32 route de Wolfisheim - 67810 HOLTZHEIM (France) - Tel. +33 3 88 78 00 23 - www.bongard.fr - bongard@bongard.fr

an Ali Group Company



The Spirit of Excellence